

Note!

Please note that this image is a general representation of the product and may differ slightly from your product.

Note!

Please note that during storage and transportation, especially at high ambient temperature, some of the oil and grease used for assembling may leak and stain the packaging. This is in no way detrimental to the product, wipe off the excessive oil/grease with a cloth.

Kit Contents

Description	Part No	Pcs
Top cap assembly		2
Pre-load tube 31.8x1.5x195	60062-10	2
Spring 35.3/300/9.0	68004-90	2
Sticker Öhlins	01185-01	2
Sticker Öhlins	01185-04	2
Sticker Öhlins	00192-01	2

Note!

Before installing this product, check the contents of the kit. If anything is missing, please contact an Öhlins dealer.

Warning!

Öhlins cannot be held responsible for any personal injury or damage that may occur after installing the Öhlins spring kit. We strongly recommend to let an Öhlins authorized service center to install this kit.

Warning!

After you have installed this product, take a test ride at low speed to be sure that your vehicle has maintained stability.

Fork Spring Kit for Royal Enfield Interceptor/ Continental GT 650

FSK 145

Mounting Instructions



MOUNTING INSTRUCTIONS

Original Front Fork assembly

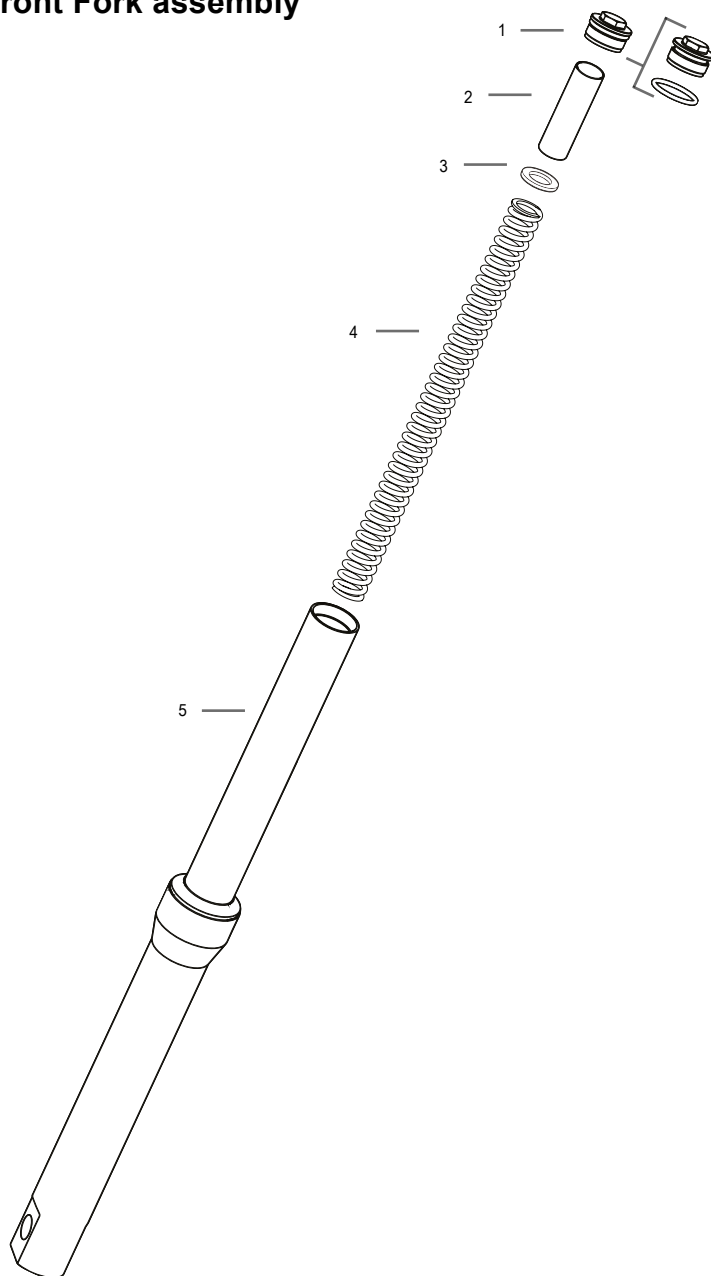

MOUNTING INSTRUCTIONS

Öhlins Front Fork kit assembly

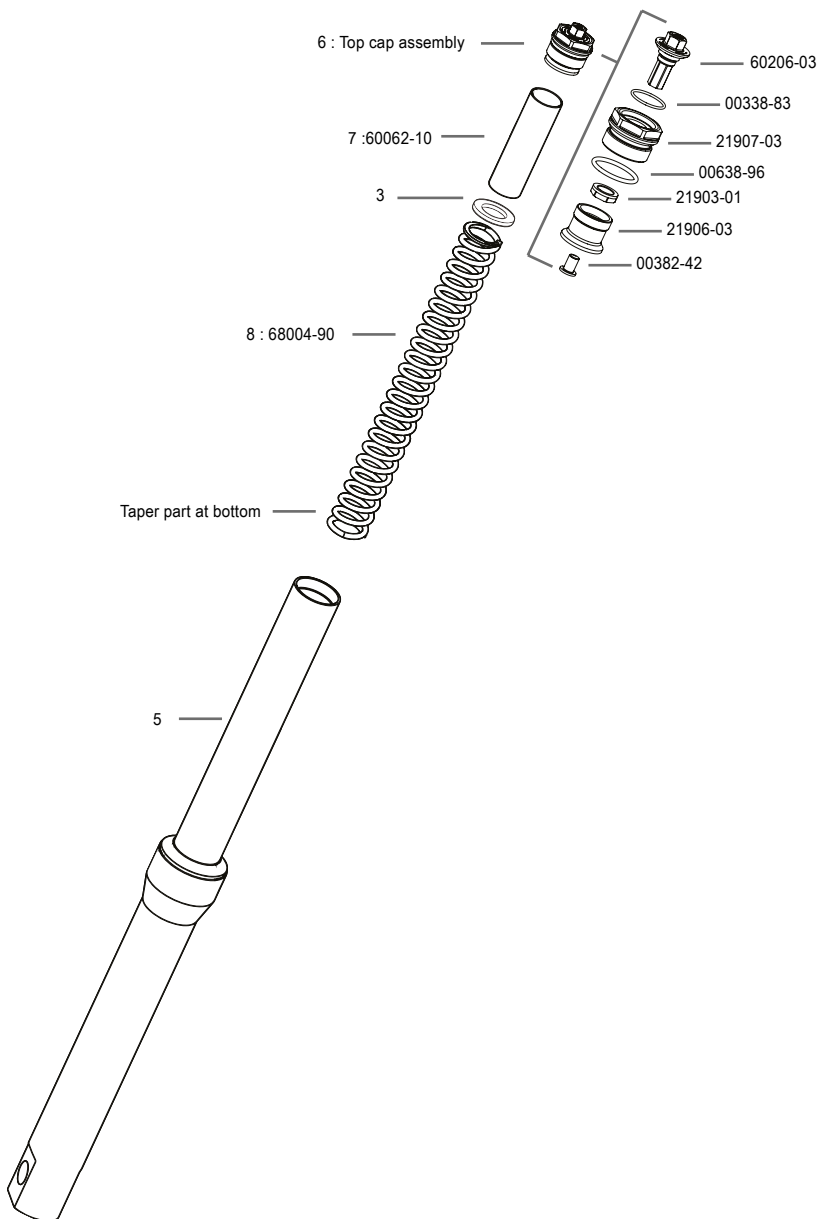

MOUNTING INSTRUCTIONS

Congratulations!

With this purchase you have made a clear statement. This high performance Front Fork spring kit from Öhlins is nothing but pure racing breed which means that you have taken one more step to eliminate luck on your motorcycle.

The balance between your Front Fork and rear suspension will sharpen up and the performance of your Front Fork will improve. 40 years of racing experience is now a crucial part of your riding experience.

Note!

Öhlins FSK 145 gives the possibility to adjust the spring preload -5/+10mm from standard preload (13mm).

> Every complete turn equals 1mm adjustment

Note!

Öhlins FSK 145 spring 68004-90 rate is 9.0 N/mm

Recommended oil

We recommended to use Öhlins high performance Front Fork fluid 01314-01.

Recommended oil level

140 mm.

Note!

The measurement of oil level is taken from the top of the inner tube (5) to the oil surface.

> The fork leg need to be in vertical position

> The fork need to be fully compressed

> The fork must be without the spring and the preload tube

Note!

During the installation of the fork damping kit, please be sure to don't loose the standard washer (3).

How to install

1. Put the motorcycle on a work stand so that the front wheel barely touches the ground. Make sure the motorcycle is in a stable position.
 2. Release the top tripleclamp screws.
 - 2.1 Loosen but don't remove, the front fork top caps.
 - 2.2 Uninstall both fork legs from the motorcycle.
 3. Remove the original Top cap (1), Pre-load tube (2), washer (3), and Spring (4)
 4. Purge all the oil from both fork legs.
 5. Fill the Öhlins oil at the recommended oil level.
 6. Insert the Öhlins spring (8), washer (3) and Öhlins Pre-load tube (7)
 7. Install the Öhlins Top cap assembly. Tighten the top cap at torque value ~ 10N/mm.
 8. Reinstall both fork legs as per vehicle service manual instructions.

Öhlins products are subject to continuous improvement and development, therefore, although these instructions include the most up-to-date information available at the time of printing, minor updates may occur.

To find the latest information contact an Öhlins distributor. Please contact Öhlins if you have any questions regarding the contents in this document.

Part no. MI_FSK145_EN_0
Issued 2019-05-03

© Öhlins Asia Co. Ltd. All rights reserved. Any reprinting or unauthorized use without the written permission of Öhlins Racing AB is prohibited.

Öhlins Asia Co. Ltd
700/937 Moo5, Tambol Nongkhaga,
Amphur Phantong, Chonburi Province
20160 Thailand



www.ohlins.com



FSK Fork Spring Kit Road & Track

FSK 145

This upgrade kit for front forks contains front fork springs as well as top caps with spring preload adjuster that adds additional function and performance to the standard fork (except Kit FSK 113 for Ducati Scrambler where the topcaps are not adjustable).

Part number

FSK 145

Technical data

Rate N/mm:	9.0 N/mm
Mounted spring:	68004-90
Recommended oil:	01314-01
Packaging unit:	kit

Fits for vehicles

[Royal Enfield Continental GT 650 \(2019\)](#)

[Royal Enfield Interceptor 650 \(2019\)](#)